

Digital Communication (Ch. 6,7,10):

Transmission consists of

1. pulse shaping: $\tilde{m}(t) = \sum_n a[n]g(t - nT)$,
2. modulation: $s(t) = \text{Re}\{\tilde{m}(t)e^{j2\pi f_c t}\}$.

Reception consists of

1. demodulation: $\tilde{v}(t) = \text{LPF}\{2r(t)e^{-j2\pi f_c t}\}$,
2. filtering: $y(t) = \tilde{v}(t) * q(t)$,
3. sampling: $y[m] = y(mT)$.

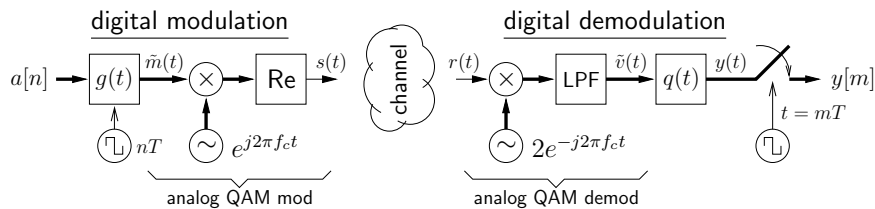

Building on analog QAM mod/demod components, digital mod adds pulse shaping & demod adds filtering/sampling.

Simplifying via the complex-baseband equivalent channel:

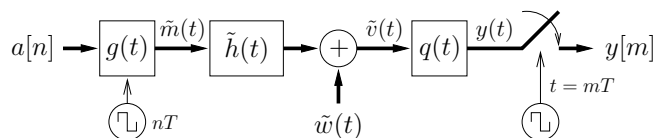

Transmitter pulse shaping is used to convert the symbol sequence $\{a[n]\}$ into the continuous message $\tilde{m}(t)$:

$$\tilde{m}(t) = \sum_n a[n]g(t - nT) \quad \text{"baseband message"}$$

$T = \text{"symbol period"}$

Thus, $\tilde{m}(t)$ can be seen to be a superposition of *scaled* and *time-shifted* copies of the pulse waveform $g(t)$.

Example, if the symbol sequence $[a[0], a[1], a[2], a[3], a[4]]$ equals $[1, 3, -1, 1, 3]$, then the square pulse $g(t)$ shown below left yields the message $\tilde{m}(t)$ shown below right.

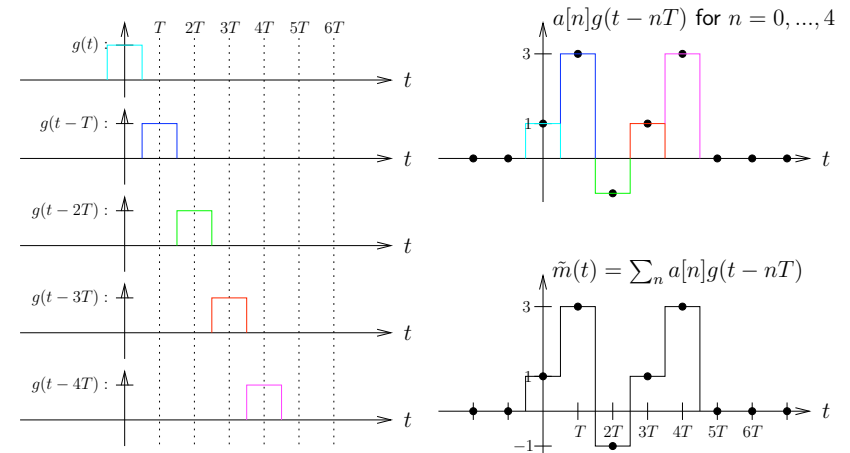

Receiver filtering (via $q(t)$) has two goals:

1. noise suppression (i.e., SNR improvement),
2. inter-symbol interference (ISI) prevention.

Noise suppression was briefly discussed on slide 13 and will soon be revisited in more detail. Next we describe ISI.

Realize that, in the *ideal* digital comm system, the n^{th} output $y[n]$ would simply equal the n^{th} input $a[n]$. But in practice, $y[n]$ can be corrupted by interference from the other symbols $\{a[m]\}_{m \neq n}$, known as “inter-symbol interference,” and noise.

ISI-prevention for the noiseless trivial channel:

Consider the idealized system

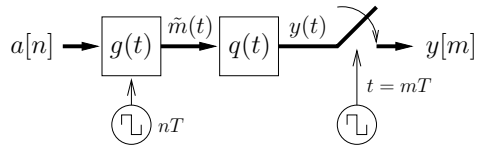

$$\begin{aligned}
 y(t) &= \int q(\tau) \tilde{m}(t - \tau) d\tau \quad \text{for } \tilde{m}(t) = \sum_n a[n] g(t - nT) \\
 &= \sum_n a[n] \int q(\tau) g(t - nT - \tau) d\tau \\
 &= \sum_n a[n] p(t - nT) \quad \text{for } p(t) = g(t) * q(t).
 \end{aligned}$$

Thus, the idealized system can be re-drawn as

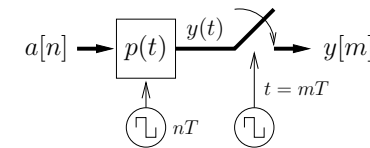

where

$$y[m] = y(mT) = \sum_n a[n] p(mT - nT) = \sum_n a[n] p((m - n)T).$$

To make $y[m] = a[m]$ (i.e., prevent ISI), we need

$$p(mT) = \begin{cases} 1 & m = 0 \\ 0 & m \neq 0 \end{cases}$$

which is known as the “Nyquist Criterion.” This criterion can be simply stated as $p(mT) = \delta[m]$ using

$$\begin{aligned}
 \delta[m] &= \begin{cases} 1 & m = 0 \\ 0 & m \neq 0 \end{cases} \quad \text{“discrete-time impulse,”} \\
 &\quad \text{or “Kronecker delta.”} \\
 a[n] &= \sum_{m=-\infty}^{\infty} a[m] \delta[n - m] \quad \text{“sifting property.”}
 \end{aligned}$$

Examples of Nyquist, and non-Nyquist, combined-pulses $p(t)$ for $[a[0], a[1], a[2], a[3], a[4]] = [1, 3, -1, 1, 3]$:

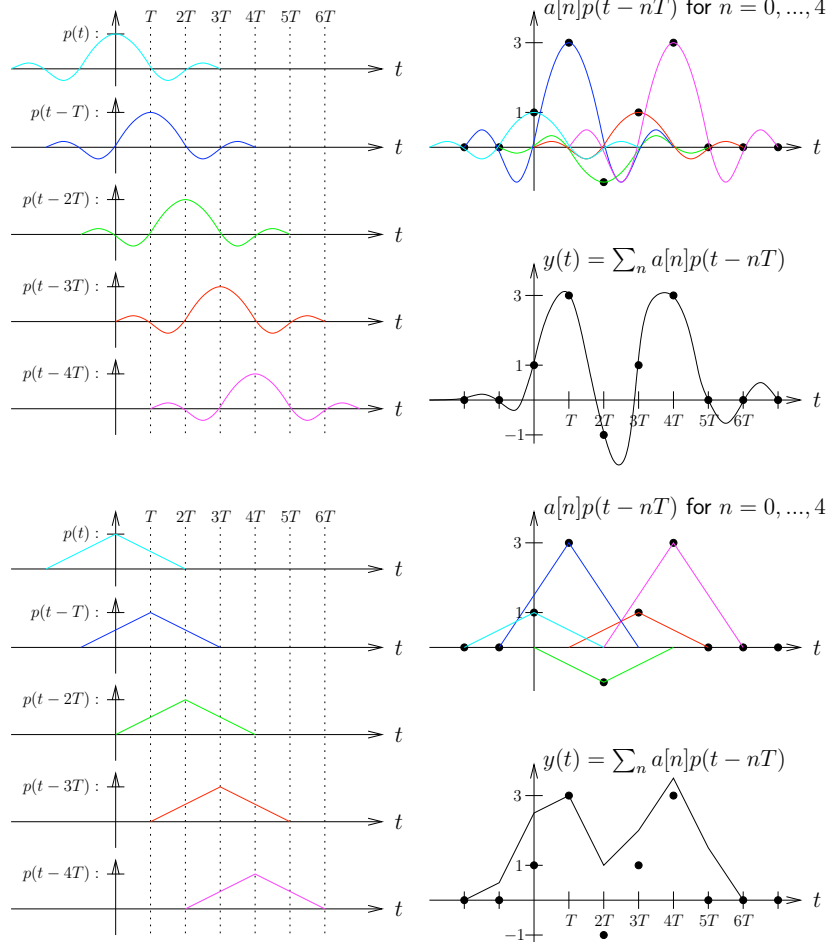

There is an interesting frequency-domain interpretation. Since

$$\frac{1}{T} \sum_{k=-\infty}^{\infty} \delta\left(f - \frac{k}{T}\right) \xleftrightarrow{\mathcal{F}} \sum_{m=-\infty}^{\infty} \delta(t - mT),$$

we can see that

$$\underbrace{P(f) * \frac{1}{T} \sum_{k=-\infty}^{\infty} \delta\left(f - \frac{k}{T}\right)}_{\frac{1}{T} \sum_{k=-\infty}^{\infty} P\left(f - \frac{k}{T}\right)} \xleftrightarrow{\mathcal{F}} \underbrace{p(t) \cdot \sum_{m=-\infty}^{\infty} \delta(t - mT)}_{\sum_{m=-\infty}^{\infty} p(mT)\delta(t - mT)}$$

So, the time-domain Nyquist criterion $p(mT) = \delta[m]$ implies

$$\frac{1}{T} \sum_{k=-\infty}^{\infty} P\left(f - \frac{k}{T}\right) \xleftrightarrow{\mathcal{F}} \delta(t),$$

which in turn implies

$$\frac{1}{T} \sum_{k=-\infty}^{\infty} P\left(f - \frac{k}{T}\right) = 1.$$

The plot shows the frequency response of the combined pulses. The x-axis is frequency f , and the y-axis is the sum of the weighted pulses. The plot shows a series of overlapping pulses centered at $f = k/T$, with a total sum of 1 for all frequencies f .

In other words, the superposition of $\left\{\frac{1}{T}P\left(f - \frac{k}{T}\right)\right\}_{k \in \mathbb{Z}}$ must sum to one. This frequency-domain version of the Nyquist Criterion will soon come in handy...

A popular choice of combined pulse $p(t) = g(t) * q(t)$ is the “raised-cosine pulse” with rolloff parameter $\alpha \in [0, 1]$:

$$p_{\text{RC}}(t) = \frac{\cos(\pi\alpha t/T)}{1 - (2\alpha t/T)^2} \text{sinc}(t/T), \quad \text{sinc}(x) := \frac{\sin(\pi x)}{\pi x}$$

$$P_{\text{RC}}(f) = \begin{cases} T & |f| \leq \frac{(1-\alpha)}{2T} \\ T \cos^2\left(\frac{\pi T}{2\alpha} \left(|f| - \frac{1-\alpha}{2T}\right)\right) & \frac{(1-\alpha)}{2T} \leq |f| \leq \frac{(1+\alpha)}{2T} \\ 0 & \frac{(1+\alpha)}{2T} \leq |f| \end{cases}.$$

Tradeoff: larger $\alpha \Rightarrow$ less time-spread but more freq-spread:

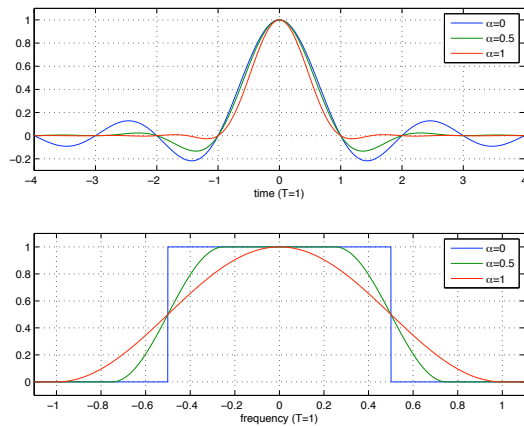

So, we now know how to design the combined pulse $p(t)$.
But what about the individual pulses $g(t)$ and $q(t)$?

Maximizing SNR for ISI-free Pulses in White Noise:

Now let's bring the noise back into consideration. Given

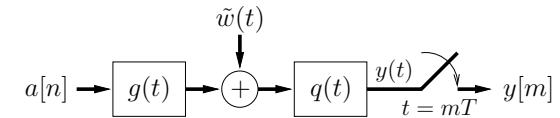

$$\mathbb{E}\{\tilde{w}(t) \tilde{w}^*(t - \tau)\} = N_0 \delta(\tau) \quad (\text{complex white noise})$$

we want $\{g(t), q(t)\}$ pair that maximizes the SNR of $y[m]$.

Separating the noise and signal contributions to $y[m]$ via

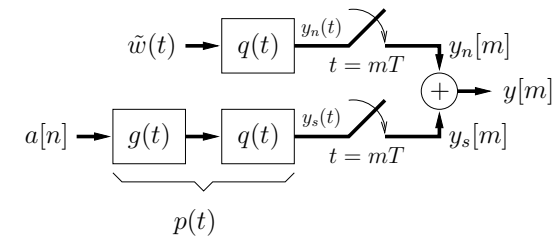

the SNR can be written

$$\text{SNR} = \frac{\mathcal{E}_s}{\mathcal{E}_n} = \frac{\mathbb{E}\{|y_s[m]|^2\}}{\mathbb{E}\{|y_n[m]|^2\}},$$

where \mathcal{E}_s and \mathcal{E}_n are average signal and noise energies.

Here, we treat both $\tilde{w}(t)$ and $a[n]$ as random, implying that $y_s[m]$ and $y_n[m]$ are both random.

Notice that, with an ISI-free combined pulse $p(t)$, we get

$$y_s[m] = \sum_n a[n]p((m-n)T) = a[m]p(0)$$

$$p(0) = \int_{-\infty}^{\infty} q(\tau)g(0-\tau)d\tau,$$

so that

$$\mathcal{E}_s = \mathbb{E}\{|y_s[m]|^2\} = \mathbb{E}\left\{\left|a[m] \int_{-\infty}^{\infty} q(\tau)g(-\tau)d\tau\right|^2\right\}$$

$$= \underbrace{\mathbb{E}\{|a[m]|^2\}}_{\sigma_a^2} \left| \int_{-\infty}^{\infty} q(\tau)g(-\tau)d\tau \right|^2,$$

where σ_a^2 denotes average symbol energy. Next, notice that

$$y_n[m] = y_n(mT) = \int_{-\infty}^{\infty} q(\tau)\tilde{w}(mT-\tau)d\tau,$$

so that

$$\mathcal{E}_n = \mathbb{E}\{|y_n[m]|^2\} = \mathbb{E}\left\{\left|\int_{-\infty}^{\infty} q(\tau)\tilde{w}(mT-\tau)d\tau\right|^2\right\}$$

$$= \mathbb{E}\left\{\int_{-\infty}^{\infty} q(\tau)\tilde{w}(mT-\tau)d\tau \int_{-\infty}^{\infty} q^*(\tau')\tilde{w}^*(mT-\tau')d\tau'\right\}$$

$$= \int_{-\infty}^{\infty} q(\tau) \int_{-\infty}^{\infty} q^*(\tau') \underbrace{\mathbb{E}\{\tilde{w}(mT-\tau)\tilde{w}^*(mT-\tau')\}}_{N_0\delta(\tau'-\tau)} d\tau'd\tau$$

$$= N_0 \int_{-\infty}^{\infty} |q(\tau)|^2 d\tau.$$

Putting these together, we find

$$\text{SNR} = \frac{\sigma_a^2}{N_0} \frac{\left|\int_{-\infty}^{\infty} q(\tau)g(-\tau)d\tau\right|^2}{\int_{-\infty}^{\infty} |q(\tau)|^2 d\tau}.$$

Cauchy-Schwarz says

$$\left|\int_{-\infty}^{\infty} b(\tau)c(\tau)d\tau\right|^2 \leq \int_{-\infty}^{\infty} |b(\tau)|^2 d\tau \cdot \int_{-\infty}^{\infty} |c(\tau)|^2 d\tau$$

with equality iff $b(\tau) = Kc^*(\tau)$ for any K ,

which implies

$$\text{SNR} \leq \frac{\sigma_a^2}{N_0} \int_{-\infty}^{\infty} |g(-\tau)|^2 d\tau$$

with equality iff $q(\tau) = Kg^*(-\tau)$ for any K .

Noting that SNR doesn't depend on K , we choose $K = 1$.

Thus, given pulse $g(t)$, the SNR-maximizing receiver filter is

$$q(\tau) = g^*(-\tau) \quad \text{known as a "matched filter"}.$$

We can write this in the frequency domain as

$$Q(f) = \int_{-\infty}^{\infty} q(\tau)e^{-j2\pi f\tau} d\tau = \int_{-\infty}^{\infty} g^*(-\tau)e^{-j2\pi f\tau} d\tau$$

$$= \int_{-\infty}^{\infty} g^*(t)e^{j2\pi ft} dt = \left[\int_{-\infty}^{\infty} g(t)e^{-j2\pi ft} dt\right]^*$$

$$= G^*(f).$$

Summary: For SNR-maximizing ISI-free pulses, we need

1. $G(f)Q(f) = P(f)$ satisfying the Nyquist crit,
2. $Q(f) = G^*(f)$,

which together imply $|G(f)|^2$ must satisfy the Nyquist crit.

One option is $G(f) = \sqrt{P_{RC}(f)}$, since $P_{RC}(f)$ was Nyquist.

We call this the “square-root raised cosine” (SRRC) pulse.

Working out the details of $\mathcal{F}^{-1}\{G_{SRRC}(f)\}$, we find

$$g_{SRRC}(t) = \frac{(1 - \alpha) \operatorname{sinc}(\frac{t}{T}(1 - \alpha))}{1 - (4\alpha\frac{t}{T})^2} + \frac{4\alpha \cos(\pi\frac{t}{T}(1 + \alpha))}{\pi(1 - (4\alpha\frac{t}{T})^2)}.$$

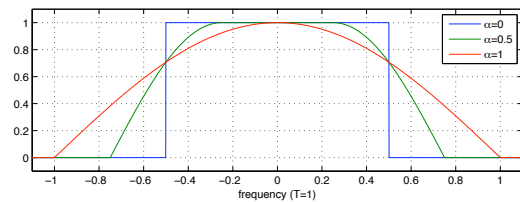
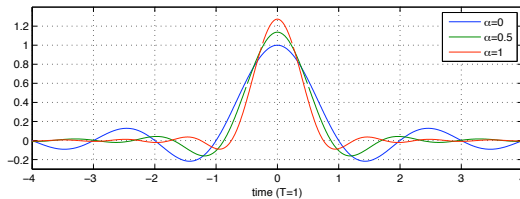

At the receiver, we would use $q_{SRRC}(t) = g_{SRRC}^*(-t) = g_{SRRC}(t)$; the latter equality is due to $g_{SRRC}(t)$ being real and symmetric.

DSP Implementation of Digital Comm:

Digital implementation of transmitter pulse-shaping and receiver filtering is much more practical than analog.

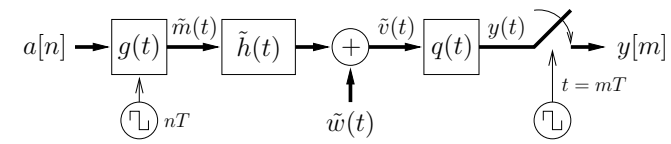

To proceed further, we need an important DSP concept called “sinc reconstruction”:

If waveform $x(t)$ is bandlimited to $\frac{1}{2T_s}$ Hz, then

$$x(t) = \sum_{n=-\infty}^{\infty} x[n] \operatorname{sinc}\left(\frac{1}{T_s}(t - nT_s)\right) \text{ for } x[n] = x(nT_s).$$

In other words, a bandlimited waveform can be reconstructed from its samples via sinc pulse shaping.

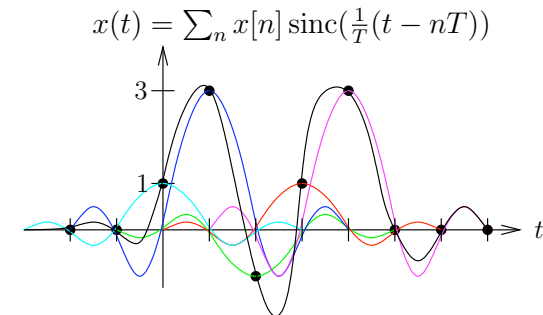

Discrete-Time Pulse-Shaping:

Applying $\frac{T}{P}$ -sampling and reconstruction to $g(t)$ (where the SRRC pulse bandwidth $\frac{1+\alpha}{2T}$ requires the use of $P \geq 2$),

$$\begin{aligned} g(\tau) &= \sum_l g[l] \operatorname{sinc}\left(\frac{P}{T}(\tau - l\frac{T}{P})\right) \quad \text{for } g[l] = g(l\frac{T}{P}) \\ \tilde{m}(t) &= \sum_n a[n] g(t - nT) \\ &= \sum_n a[n] \sum_l g[l] \operatorname{sinc}\left(\frac{P}{T}(t - nT - l\frac{T}{P})\right) \\ &= \sum_n a[n] \sum_k g[k - nP] \operatorname{sinc}\left(\frac{P}{T}(t - k\frac{T}{P})\right) \quad \text{via } k = nP - l \\ &= \sum_k \underbrace{\sum_n a[n] g[k - nP]}_{:= \tilde{m}[k]} \operatorname{sinc}\left(\frac{P}{T}(t - k\frac{T}{P})\right) \end{aligned}$$

The sequence $\tilde{m}[k]$, a weighted sum of P -shifted pulses $g[k]$, can be generated by P -upsampling $a[n]$ (i.e., inserting $P-1$ zeros between every pair of samples) and filtering with $g[k]$:

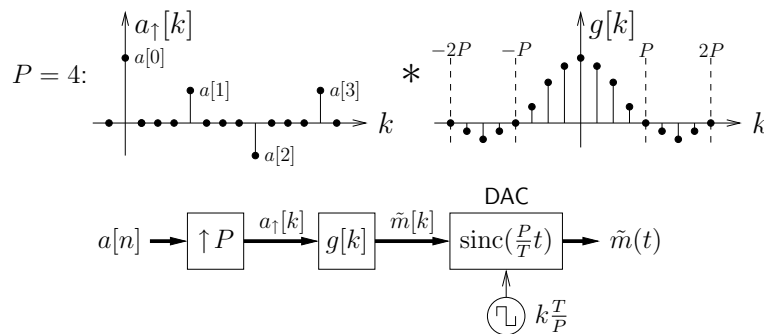

Note: sinc-pulse shaping = digital-to-analog conversion (DAC).

Discrete-Time Receiver Filtering:

Applying $\frac{T}{P}$ -sampling and reconstruction to bandlimited $q(\tau)$:

$$q(\tau) = \sum_{l=-\infty}^{\infty} q[l] \operatorname{sinc}\left(\frac{P}{T}(\tau - l\frac{T}{P})\right) \quad \text{for } q[l] = q(l\frac{T}{P})$$

where again we need $P \geq 2$, yields

$$\begin{aligned} y_{\uparrow}[k] &= y(k\frac{T}{P}) = \int_{-\infty}^{\infty} q(\tau) \tilde{v}(k\frac{T}{P} - \tau) d\tau \\ &= \int_{-\infty}^{\infty} \sum_{l=-\infty}^{\infty} q[l] \operatorname{sinc}\left(\frac{P}{T}(\tau - l\frac{T}{P})\right) \tilde{v}(k\frac{T}{P} - \tau) d\tau \\ &= \sum_{l=-\infty}^{\infty} q[l] \underbrace{\int_{-\infty}^{\infty} \operatorname{sinc}\left(\frac{P}{T}\tau'\right) \tilde{v}\left((k-l)\frac{T}{P} - \tau'\right) d\tau'}_{\{\operatorname{sinc}(\frac{P}{T}t) * \tilde{v}(t)\}_{t=(k-l)\frac{T}{P}} = \tilde{v}[k-l]} \\ &= \sum_{l=-\infty}^{\infty} q[l] \tilde{v}[k-l] = q[k] * \tilde{v}[k], \end{aligned}$$

from which $y[m]$ is obtained by keeping only every P^{th} sample:

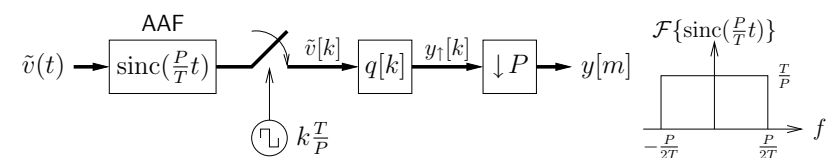

i.e., downsampling. Here $\operatorname{sinc}(\frac{P}{T}t)$ does anti-alias filtering.

Discrete-Time Complex-Baseband Channel:

Finally, we derive a discrete-time representation of the channel between $\tilde{m}[k]$ and $\tilde{v}[k]$:

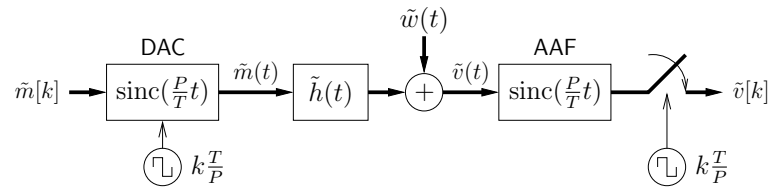

Using $\tilde{w}[k]$ to refer to the noise component of $\tilde{v}[k]$, it can be seen from the block diagram that

$$\tilde{w}[k] = \int_{-\infty}^{\infty} \tilde{w}(\tau) \text{sinc}\left(\frac{P}{T}\left(k\frac{T}{P} - \tau\right)\right) d\tau$$

To model the signal component of $\tilde{v}[k]$, realize that $\tilde{m}[k]$ is effectively pulse-shaped by $\text{sinc}\left(\frac{P}{T}t\right) * \tilde{h}(t) * \text{sinc}\left(\frac{P}{T}t\right)$. But since the frequency response of $\text{sinc}\left(\frac{P}{T}t\right)$ has a flat gain of $\frac{T}{P}$ over the signal bandwidth, and thus the bandwidth of $\tilde{h}(t)$,

$$\text{sinc}\left(\frac{P}{T}t\right) * \tilde{h}(t) * \text{sinc}\left(\frac{P}{T}t\right) = \frac{T^2}{P^2} \tilde{h}(t).$$

So, with $\frac{T}{P}$ -sampling and reconstruction of $\frac{T^2}{P^2} \tilde{h}(t)$, i.e.,

$$\frac{T^2}{P^2} \tilde{h}(t) = \sum_{i=-\infty}^{\infty} h[i] \text{sinc}\left(\frac{P}{T}\left(t - i\frac{T}{P}\right)\right) \quad \text{for } h[i] = \frac{T^2}{P^2} h\left(i\frac{T}{P}\right)$$

we can write $\tilde{v}[k]$ as

$$\begin{aligned} \tilde{v}[k] &= \tilde{w}[k] + \sum_l \tilde{m}[l] \frac{T^2}{P^2} \tilde{h}\left(k\frac{T}{P} - l\frac{T}{P}\right) \\ &= \tilde{w}[k] + \sum_l \tilde{m}[l] \sum_i \tilde{h}[i] \underbrace{\text{sinc}\left(k - l - i\right)}_{\delta[k - l - i]} \\ &= \tilde{w}[k] + \sum_l \tilde{m}[l] \tilde{h}[k - l] \end{aligned}$$

yielding the discrete-time channel

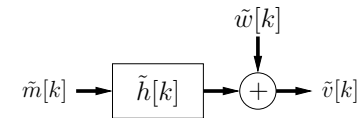

Merging the discrete-time channel with the discrete-time modulator and demodulator yields

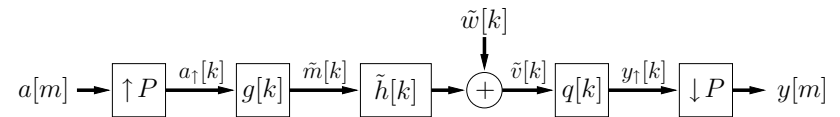

known as the “fractionally sampled” system model. This model is very convenient for MATLAB simulation and acts as a foundation for further analysis.